



Dichiarazione CE di conformità
EC declaration of conformity

Torino, 1/1/2010

REER SpA
via Carcano 32
10153 – Torino
Italy

dichiara che le barriere fotoelettriche **JANUS TRX / M TRX** sono Dispositivi Elettrosensibili di Sicurezza (ESPE) di :

- **Tipo 4** (secondo la Norma *CEI EN 61496-1:2005; CEI EN 61496-2:2007*)
- **SIL 3** (secondo la Norma *CEI EN 61508:2002*)
- **SILCL 3** (secondo la Norma *CEI EN 62061:2005 + CEI EN 62061/EC2:2008*)
- **PL e** (secondo la Norma *UNI EN ISO 13849-1:2008*)

declares that the **JANUS TRX / M TRX** photoelectric safety barriers are :

- **Type 4** (according the Standard *IEC 61496-1:2004; IEC 61496-2:2006*)
- **SIL 3** (according the Standard *IEC 61508:1998*)
- **SILCL 3** (according the Standard *IEC 62061:2005*)
- **PL e** (according the Standard *ISO 13849-1:2006*)

Electro-sensitive Protective Equipments (ESPE)

realizzati in conformità alle seguenti Direttive Europee:
complying with the following European Directives:

- **2006/42/CE** "Direttiva Macchine"
"Machine Directive"
- **2004/108/CE** "Direttiva Compatibilità Elettromagnetica"
"Electromagnetic Compatibility Directive"
- **2006/95/CE** "Direttiva Bassa Tensione"
"Low Voltage Directive"

e sono identiche all'esemplare esaminato ed approvato con esame di tipo CE da:
and are identical to the specimen examined and approved with a CE - type approval by:

TÜV SÜD Rail GmbH – Ridlerstrasse 65 – D-80339 – Muenchen – Germany

Carlo Pautasso
Direttore Tecnico
Technical Director

Giancarlo Scaravelli
Presidente
President

*PHOTOELECTRIC
SAFETY
BARRIER*

JANUS TRX

INSTALLATION USE AND MAINTENANCE

INDICE

INTRODUCTION	2
PRINCIPLE OF OPERATION.....	3
INSTALLATION	4
POSITION	5
MULTIPLE SYSTEMS	5
SAFETY DISTANCE CALCULATION.....	6
VERTICAL POSITION OF THE BARRIER.....	7
ELECTRICAL CONNECTIONS	7
EXTERNAL CONNECTION	8
DISTANCE BETWEEN REFLECTING SURFACES	9
MOUNTING AND OPTICAL ALIGNMENT	11
OPERATION AND TECHNICAL DATA	12
SIGNALS.....	12
CONFIGURATION AND OPERATION MODES.....	13
K1/K2 EXTERNAL CONTACTORS CONNECTION.....	16
OUTPUT STATUS	16
TECHNICAL SPECIFICATIONS.....	17
DIMENSIONS	18
CHECKOUTS AND MAINTENANCE	18
TROUBLESHOOTING	19
SPARE PARTS.....	21
GUARANTEE	22



This symbol stands by a very important warning concerning the safety of persons. Its non-observance can cause a very serious risk for the exposed personnel.

INTRODUCTION

The JANUS TRX photoelectric barrier is a double-beam optoelectronic safety system.

It belongs to the family of Type 4 electrosensitive devices for the protection of personnel exposed to risks arising from the use of hazardous machinery or plant, according to standards IEC 61496-1,2 and EN 61496-1.

This barrier is composed of one **active element J TRX E/R** (containing the emitter and the receiver units) and one **passive element J TRX RR** with a retroreflector pre-aligned inside) which reflects the infrared beam (Figure 1).

The distance between the axis of the 2 beams (emitted and reflected) is 500mm (value required by the EN999 European Normative for a 2-beams System).

A diagnostic display available on the active element provides the necessary informations for a correct use of the device and the valuation of the possible operation failures.

JANUS TRX is ideal for protecting:

Automatic palletizing/depalletizing systems, packing and packaging machines, metal, wood, marble and glass tool machines, materials handling.



If necessary, for any safety-related problems contact the competent safety authorities or industrial associations in the country of use.



For applications in the food industry, please contact the manufacturer to ensure that the barrier contains materials that are compatible with the chemical agents utilized.

The protective function of the optoelectronic devices is not effective in the following cases:



If the machine stopping control cannot be actuated electrically and it is not possible to stop all dangerous machine movements immediately and at any time during the operating cycle.



If the machine generates dangerous situations due to material being expelled or falling from overhead.

PRINCIPLE OF OPERATION

Figure 1 shows the JANUS TRX way of operation :

The active element **J TRX E/R** contains the *emitter* and the *receiver* units; the emitted infrared beam, correctly reflected by the two pre-aligned deflection mirrors of the passive element **J TRX RR**, is received by the receiver of the **J TRX E/R**.

With the protected area clear, the two PNP outputs of the active elements are in ON condition (24VDC) and guarantee the normal operation of the connected machine.

When an object interrupts the infrared beams, the TRX PNP outputs are de-energized (OFF condition - 0VDC). This condition permits to stop the moving body of the machine (thanks to a specific stopping circuit).

**ACTIVE
ELEMENT
J TRX E/R**

**PASSIVE
ELEMENT
J TRX RR**

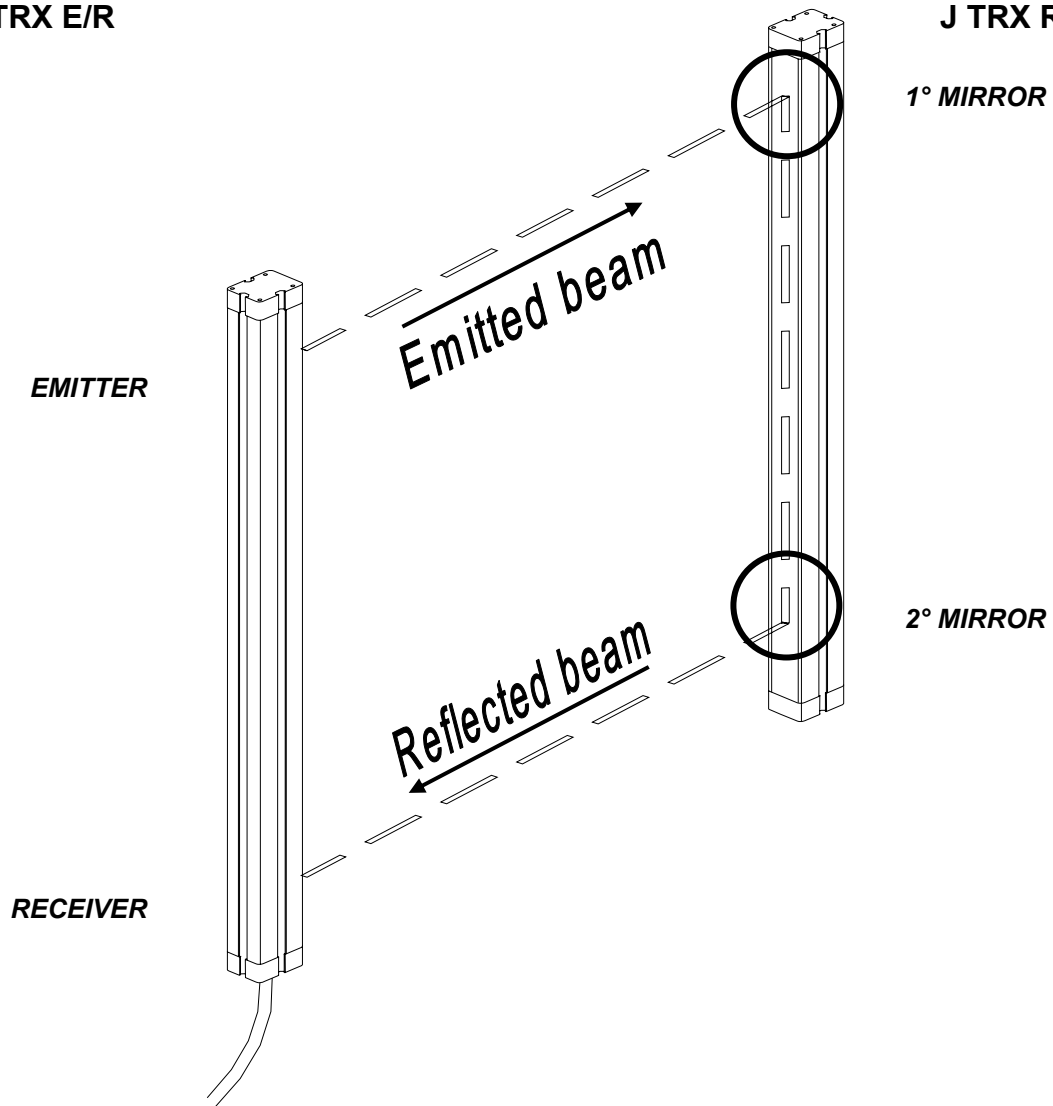







Figure 1

INSTALLATION



Before installing the JANUS TRX safety system, make sure that:

-  ***The safety system is only used as a stopping device and not as a machine control device.***
-  ***The machine control can be actuated electrically.***
-  ***All dangerous machine movements can be interrupted immediately. In particular, the machine stopping times must be known and, if necessary, measured.***
-  ***The machine does not generate dangerous situations due to materials projecting or falling from overhead; if that is not the case, additional mechanical guards must be installed.***
-  ***The minimum dimensions of the object that must be intercepted are greater than or equal to the resolution of the JANUS TRX.***

Knowledge of the shape and dimensions of the dangerous area enables the width and height of the relative access area to be calculated.

-  ***Compare these dimensions with the maximum working range and the height of the protected area in relation to the JANUS TRX.***

The general instructions set out below must be taken into consideration before placing the safety device in position.

-  ***Make sure that the temperature of the environment in which the system is to be installed is compatible with the temperature parameters contained in the technical data sheet.***
-  ***Do not install the active unit close to bright or high-intensity flashing light sources.***
-  ***Certain environmental conditions may affect the monitoring capacity of the photoelectric devices. In order to assure correct operation of equipment in places that may be subject to fog, rain, smoke or dust, the appropriate correction factors C_f should be applied to the maximum working range values. In these cases:***

$$P_u = P_m \times C_f$$

where P_u and P_m are, respectively, the working and maximum range in meters.

The recommended Cf factors are shown in the table below:

ENVIRONMENTAL CONDITION	CORRECTION FACTOR Cf
Fog	0.25
Steam	0.50
Dust	0.50
Dense fumes	0.25



If the device is installed in places that are subject to sudden changes in temperature, the appropriate precautions must be taken in order to prevent the formation of condensation on the lenses, which could have an adverse effect on monitoring.

POSITION

The active **J TRX E/R** and passive elements **J TRX RR** must be positioned in such a way that the access to the dangerous zone from overhead, bottom and from the opposite sides is **impossible** without intercepting at least one of the two optical beams.

WARNING
To reach the perfect JANUS TRX installation, position both the units as showed in Figure 2 (REER labels in the same side)

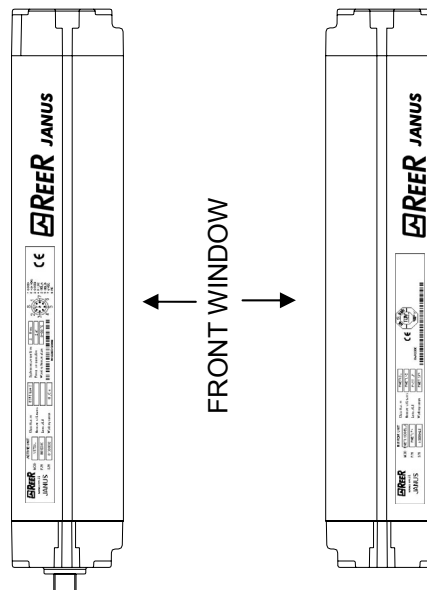

Figure 2

MULTIPLE SYSTEMS

JANUS TRX is composed of one active and one reflecting element; when more than one JANUS TRX system is used, precaution must be taken to avoid optical interference between them.

We recommend to interpose between two adjacent systems, opportune NOT TRANSPARENT surfaces to stop the passage of the infrared beam.

SAFETY DISTANCE CALCULATION

The barrier must be installed at a distance that is greater than or equal to the **minimum safety distance S**, so that a dangerous point can only be reached after all hazardous machine movements have stopped (Figure 3).

According to European standard EN999, the minimum safety distance **S** must be calculated using the following formula:

$$S = K (t_1 + t_2) + C$$

where:

S	<i>minimum safety distance</i>	mm
K	<i>approach speed of object to the dangerous area</i>	mm/sec
t₁	<i>response time of the safety barrier in seconds</i>	sec
t₂	<i>machine response time, in seconds, meaning the time required for the machine to interrupt the dangerous movement following transmission of the stop signal</i>	sec
c	<i>additional distance</i>	mm



The non-observance of the correct safety distance reduces or cancels the protective action of the light curtain.



If the position of the barrier does not prevent the operator from having access to the dangerous area without being detected, additional mechanical guards must be installed to complete the system.

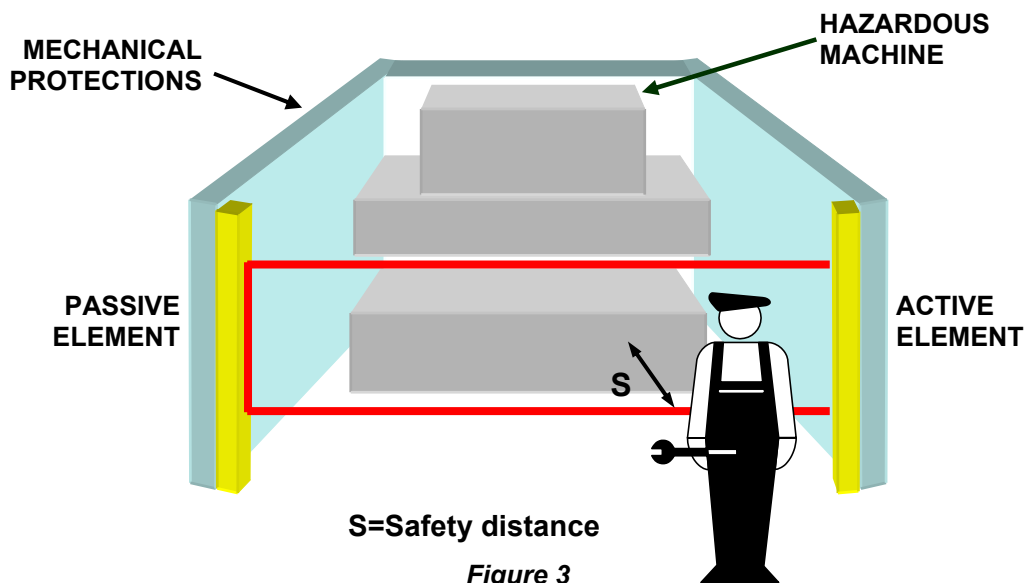

VERTICAL POSITION OF THE BARRIER



These models are suitable for the protection of the entire body and must not be used to protect arms or legs.

The minimum safety distance **S** is calculated according to the following formula:

$$S = 1600 (t_1 + t_2) + 850$$



The recommended height **H** from the reference surface **G** (ground) is as follows:

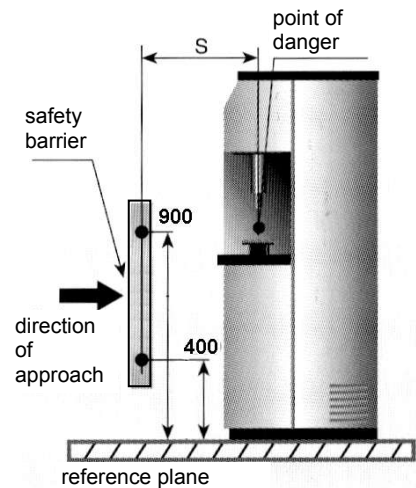

Figure 4

MODEL	BEAMS	Reccomended Height H (mm)
J TRX E/R	2	400 – 900

ELECTRICAL CONNECTIONS

WARNINGS

Before making the electrical connections, make sure that the supply voltage complies with the one specified in the technical data sheet.



Janus TRX must be supplied with $24V_{dc} \pm 20\%$ power supply. The external power supply must comply with the standard EN 60204-1.

The electrical connections must be made according to the diagrams in this manual. In particular, do not connect other devices to the connectors of the active unit.

To guarantee reliability of operation, when using a diode jumper supply unit, its output capacity must be at least 2000 μ F for each absorbed **A**.

Connector pins.

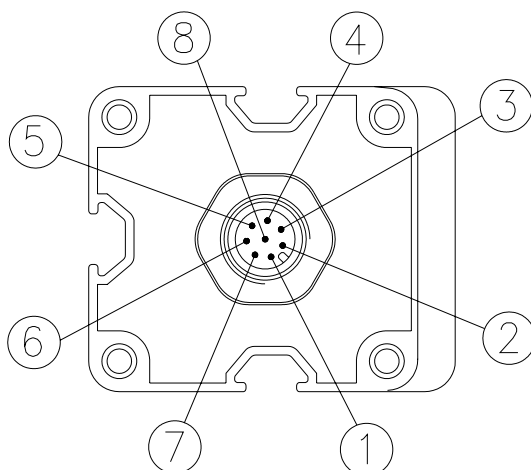

Figure 5

EXTERNAL CONNECTION

PIN	COLOR	NAME	TYPE	DESCRIPTION	OPERATION
2	<i>Brown</i>	24VDC	-	24VDC power supply	-
7	<i>Blue</i>	0VDC	-	0VDC	-
8	<i>Red</i>	PE	-	Ground connection	-
1	<i>White</i>	OSSD1	OUTPUT	Safety static outputs	PNP active high
3	<i>Green</i>	OSSD2	OUTPUT		
5	<i>Grey</i>	EXT_SEL_A	INPUT	Barrier configuration	According the normative EN61131-2 (ref. Table 2 and Table 3)
6	<i>Pink</i>	EXT_SEL_B	INPUT		
4	<i>Yellow</i>	EXT_K1_K2	INPUT	Feedback external contactors	

Table 1

Warnings regarding the connection cables

- For connections over 50m long, use cables with a cross-section area of 1 mm².
- The power supply to the barrier should be kept separate from that to other electric power equipment (electric motors, inverters, frequency converters) or other sources of disturbance.
- Connect the active element to the ground output.
- The connection cables must follow a different route to that of the other power cables.

DISTANCE BETWEEN REFLECTING SURFACES

The presence of reflecting surfaces in proximity of the photoelectric barrier may generate spurious reflections that prevent monitoring. With reference to Figure 6, object **A** is not detected because surface **S** reflects the beam and closes the optical path between the active and passive elements.

A minimum distance **d** must therefore be maintained between any reflecting surfaces and the protected area. The minimum distance **d** must be calculated according to the distance **l** between the active and passive unit, considering that the angle of projection and reception is 4°.

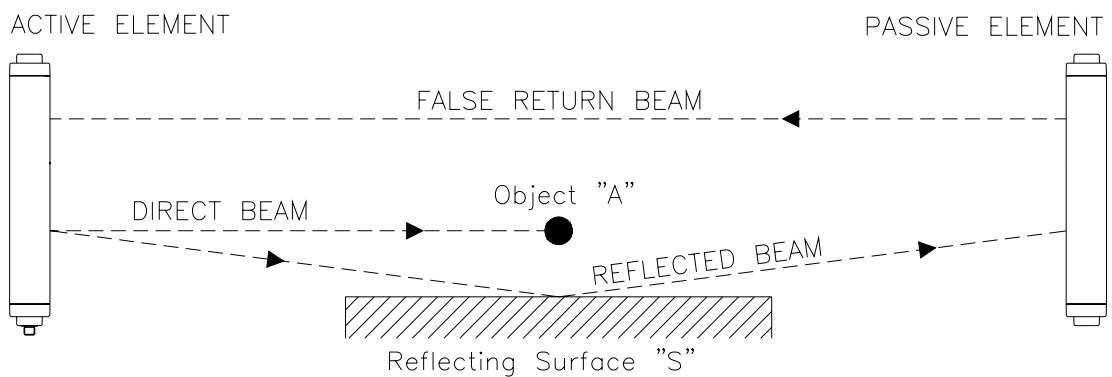
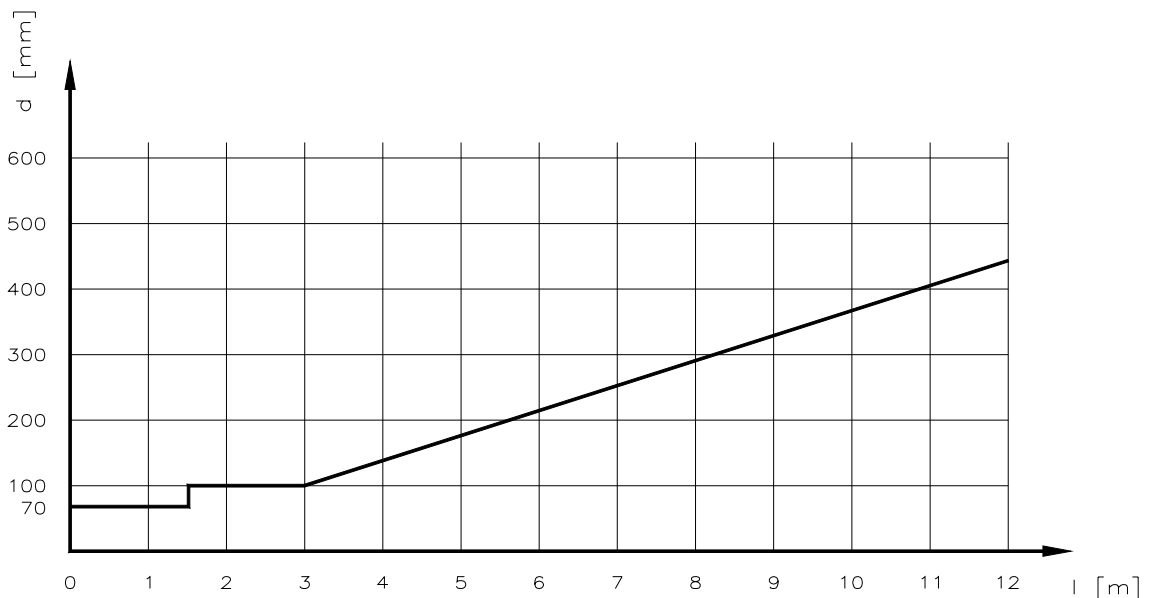

Figure 6

Figure 7 illustrates the values for the minimum distance **d** that must be maintained when the distance **l** between the active and passive elements is changed.



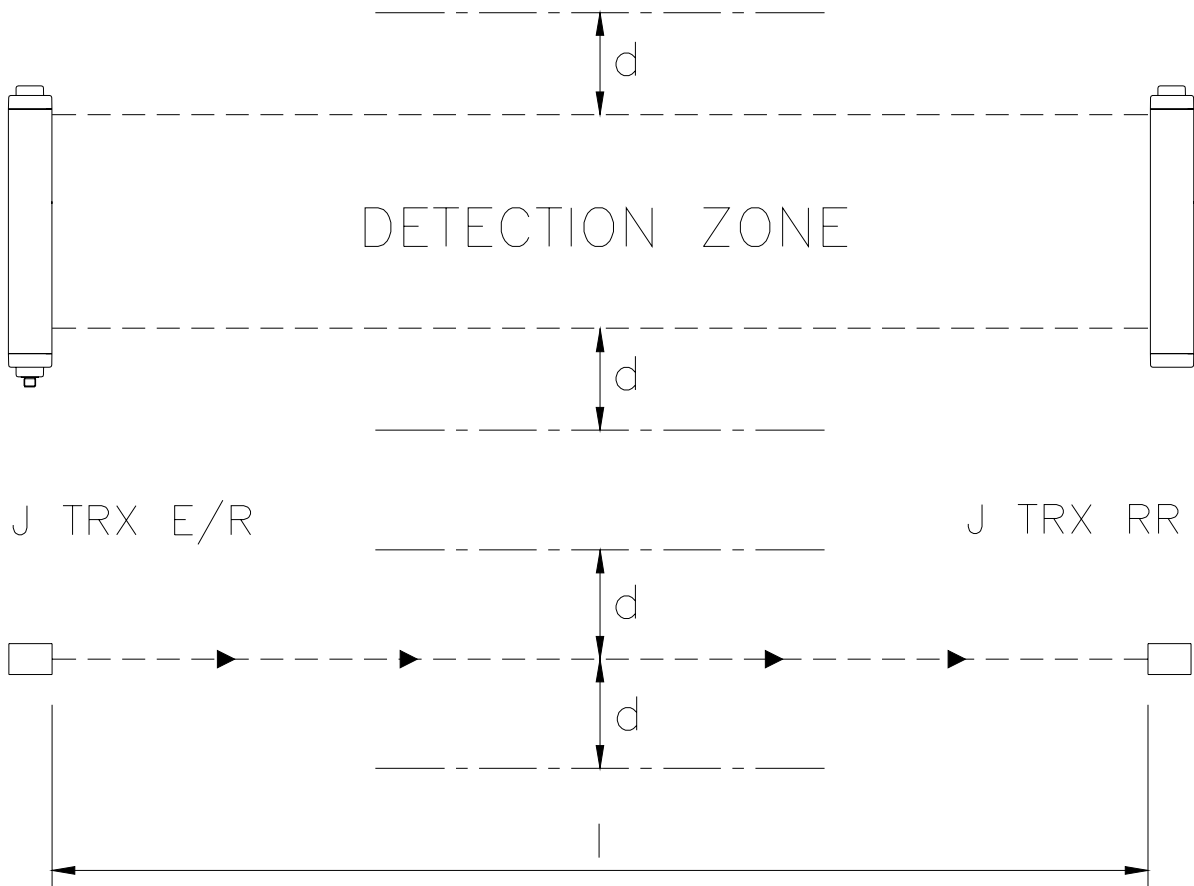

Figure 7

After installing the system, check whether any reflecting surfaces intercept the beams, first in the centre and then in the vicinity of the active unit.

During these operations, the red LED on the active elements should never, for any reason, switch off.

MOUNTING AND OPTICAL ALIGNMENT

The active element **J TRX E/R** and the the passive element **J TRX RR** must be mounted the first in front of the other with the same (or less) distance showed in the technical data.

Using the **fastening brackets and inserts** (available on request) fix the active element J TRX E/R and the passive element J TRX RR aligned and parallel.

The fastening inserts can be located in the rear or in the side spline of the units, depending on the dimensions and shape of the machine rest (Figure 8). **The bracket supplied with the barrier must be fixed in the vertical center of the columns.**

The perfect alignment between the two units is essential for the correct barrier operation; the control of the signal leds makes this function easier.

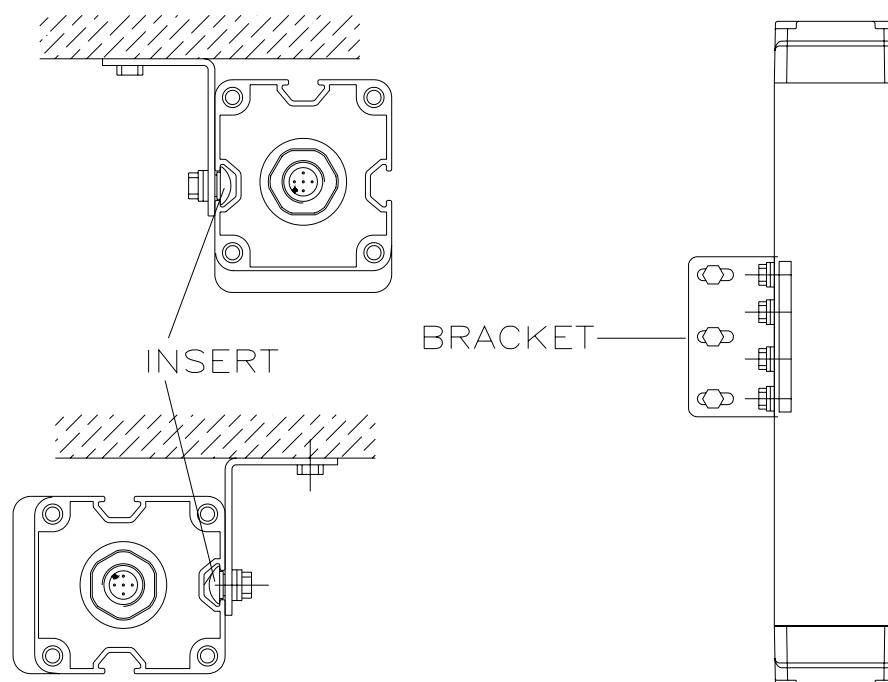

Figure 8

- Place the optical axis of the photoemitter and photoreceiver on the same axis of the reflecting mirrors of the passive element.
- Hold the passive element and move J TRX E/R to find the area within which the green led stays on, then position the first beam (the one close to the indicator leds) in the centre of this area.
- Lock the two units in place.

During these operations it may be useful to check the **orange weak signal LED** on the passive element. Upon completion of alignment, this LED must be off.

If the active element is assembled in areas that are subject to strong vibrations, the use of vibration-damping supports is recommended, in order to prevent circuit malfunctions.

OPERATION AND TECHNICAL DATA

SIGNALS

The symbols showed on the 7 segments display of the active elements,
The symbols showed on the 7 segments display and the leds of the active elements are visualized depending on the system operation phase. The tables below shows the different signals (ref. Figure 9).

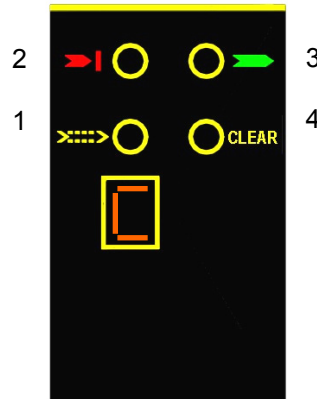

Figure 9

Normal operation (FIX SYMBOLS)

SYMBOL	LED				MEANING
	RED (2)	GREEN (3)	YELLOW (4)	ORANGE (1)	
8	ON	ON	ON	ON	System power on. Initial TEST
C Lighted for 10seconds	OFF	OFF	OFF	OFF	Manual with feedback disabled
	OFF	OFF	ON	OFF	Manual with feedback enabled
	OFF	OFF	OFF	ON	Automatic with feedback disabled
	OFF	OFF	ON	ON	Automatic with feedback enabled
-	ON	OFF	OFF	OFF	BREAK condition (A)
-	OFF	OFF	ON	OFF	CLEAR condition (B)
-	OFF	ON	OFF	OFF	GUARD condition (C)
-	OFF	OFF	ON	ON	CLEAR condition with weak signal
-	OFF	ON	OFF	ON	GUARD condition with weak signal

(A) Barrier occupied - output disabled

(B) Barrier free - output disabled - Waiting for restart

(C) Barrier free - output enabled

Configuration errors (BLINKING SYMBOLS)

SYMBOL	LED				MEANING
	RED (2)	GREEN (3)	YELLOW (4)	ORANGE (1)	
C	ON	OFF	OFF	OFF	Customer configuration rejected
2	ON	OFF	OFF	OFF	OSSD erroneously connected to 24VDC
E	ON	OFF	OFF	OFF	External Feedback contactors missed

N.B.: For the meaning of the number that is displayed in case of a malfunction, please refer to the "TROUBLESHOOTING" paragraph in this manual.

CONFIGURATION AND OPERATION MODES

The JANUS TRX operation mode is selected realizing appropriate connections on the M12 8 poles of the active element (Table 1 and Table 2).

AUTOMATIC MODE

In this operation mode the OSSD1 and OSSD2 safety outputs follow the barrier status :

- with protected area clear, the safety outputs are active.
- with protected area intercepted, the safety outputs are disabled.

CONNECTION			OPERATION MODE
EXT_SEL_A (PIN 5) connected to : ext_OSSD1 (PIN 1)	EXT_SEL_B (PIN 6) connected to : ext_OSSD2 (PIN 3)	EXT_K1_K2 (PIN 4) connected to : 0VDC	AUTOMATIC without K1-K2 feedback
EXT_SEL_A (PIN 5) connected to : ext_OSSD2 (PIN 3)	EXT_SEL_B (PIN 6) connected to : ext_OSSD1 (PIN 1)	EXT_K1_K2 (PIN 4) connected to : 24VDC (through series of contacts N.C. of external relays)	AUTOMATIC with K1-K2 feedback

Table 2

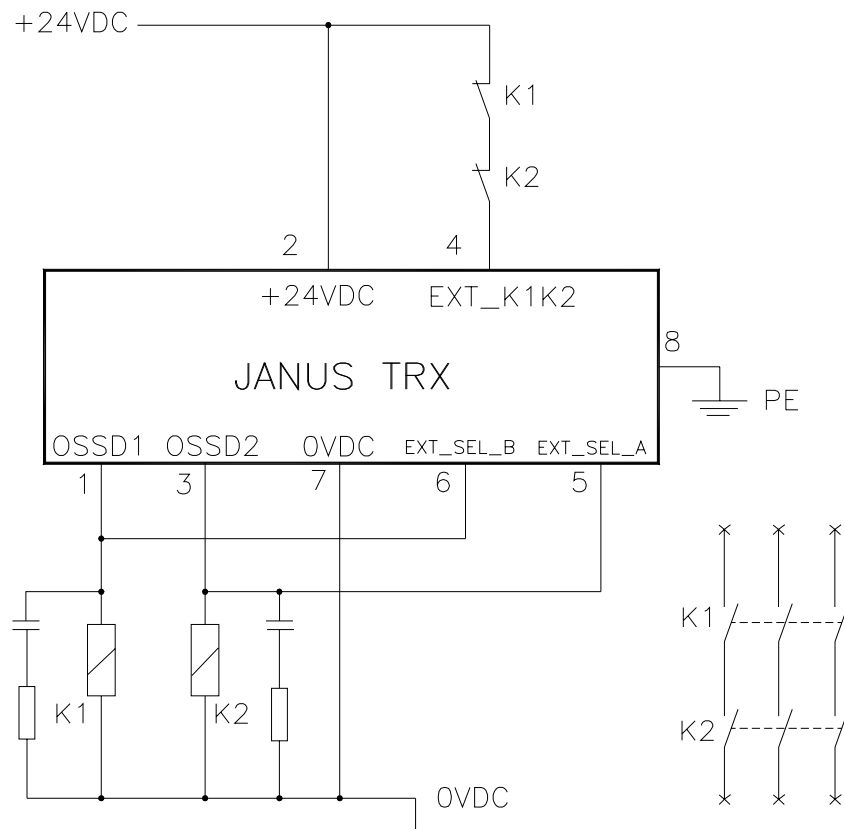

Figure 10

Example of connection of TRX barrier in AUTOMATIC mode with feedback K1K2

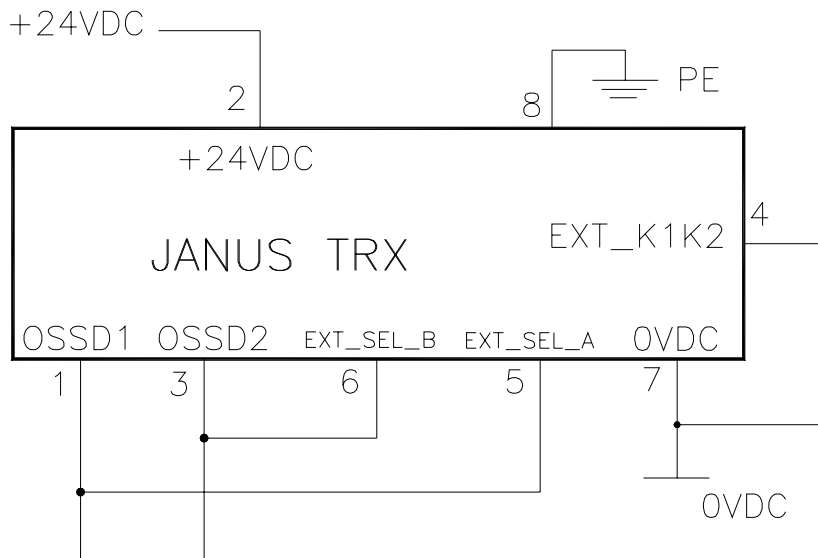

Figure 11

Example of connection of TRX barrier in AUTOMATIC mode without feedback K1K2

MANUAL MODE

In this operating mode the safety outputs OSSD1 and OSSD2 are activated (+24VDC) only if the protected area is free and after the reception of the RESTART signal, using a push button or thank to an appropriate control on the SEL_A or SEL_B input (ref.Table 3).

After an interception of the protected area, the safety outputs will be de-activated. To re-activate them it will be necessary to repeat the sequence described above.

The RESTART command is active with a voltage of +24VDC.

The minimum duration of the RESTART command is 400ms.



Use of manual mode (start/restart interlock activated) is compulsory if the safety device controls an opening to protect a danger area and a person, after passing through the opening, may remain in the danger area without being detected (use as 'trip device' according to IEC 61496). Failure to comply with this rule may result in very serious hazards for the persons exposed.

CONNECTION			OPERATION MODE
EXT_SEL_A (PIN 5) connected to : 24VDC (PIN 2)	EXT_SEL_B (PIN 6) connected to : 24VDC (PIN 2) (through the RESTART pushbutton)	EXT_K1_K2 (PIN 4) connected to : 0VDC	MANUALE senza feedback K1-K2
EXT_SEL_A (PIN 5) connected to : 24VDC (PIN 2) (through the RESTART pushbutton)	EXT_SEL_B (PIN 6) connected to : 24VDC (PIN 2)	EXT_K1_K2 (PIN 4) connected to : 24VDC (through series of contacts N.C. of external relays)	MANUALE con feedback K1-K2

Table 3

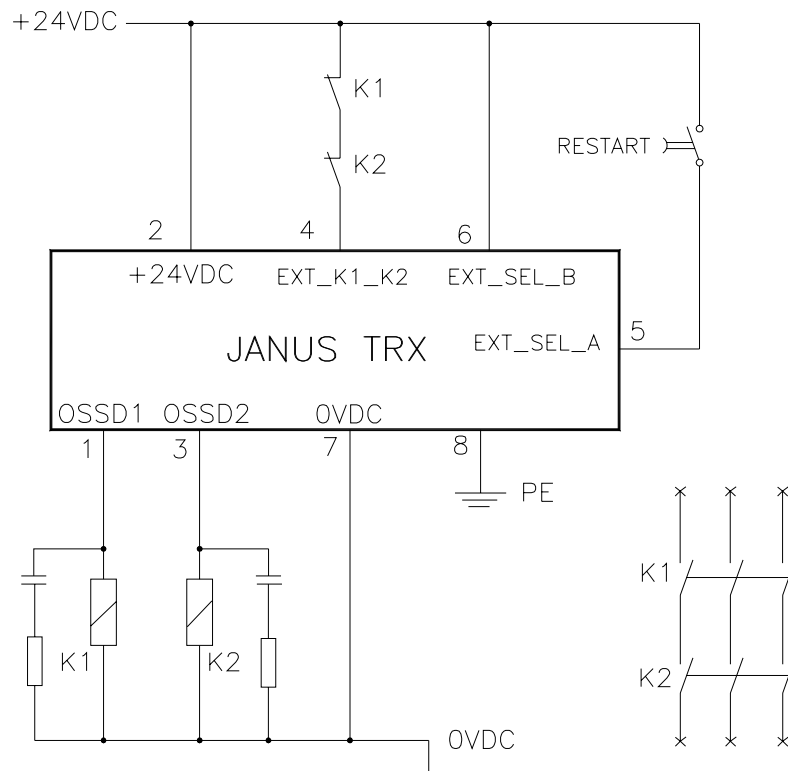

Figure 12

Example of connection of TRX barrier in MANUAL mode with feedback K1K2

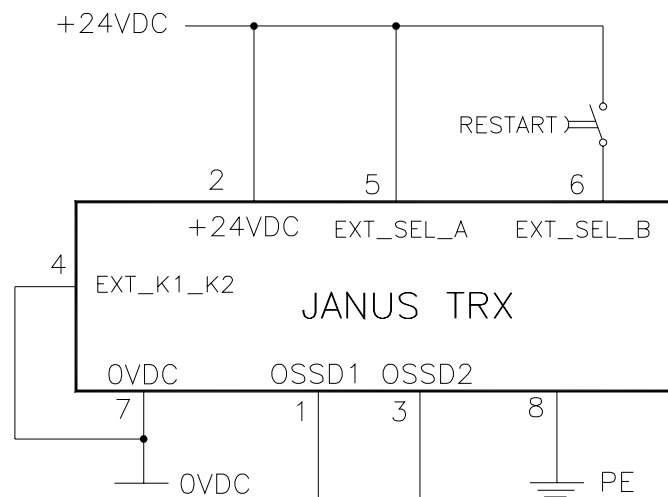

Figure 13

Example of connection of TRX barrier in MANUAL mode without feedback K1K2

K1/K2 EXTERNAL CONTACTORS CONNECTION

In every operating mode is activable the K1/K2 external contactors feedback.

If you want to use this check, connect the pin 4 of 8 poles M12 connector with the power supply (+24VDC) through the series of N.C. contacts (feedback) of external contactors.

OUTPUT STATUS

Janus TRX features two static PNP outputs on the active element, the status of which depends on the condition of the protected area.

The maximum load allowed is 500mA at 24VDC, which corresponds to a resistive load of 48Ω. Maxim load capacity corresponds to 2.2μF. The meaning of the status of outputs is defined in the table below. Any short circuit between outputs or between outputs and 24VDC or 0VDC power supplies is detected by the barrier.

NAME OF SIGNAL	CONDITION	MEANING
OSSD1	24VDC	Condizione di barriera libera.
OSSD2		
OSSD1	0VDC	Condizione di barriera occupata o guasto riscontrato
OSSD2		

Table 4



In the protected area clear condition, the active element supplies a voltage of 24 VDC on both outputs. The required load must therefore be connected between the output terminals and the 0VDC (Figure 14).

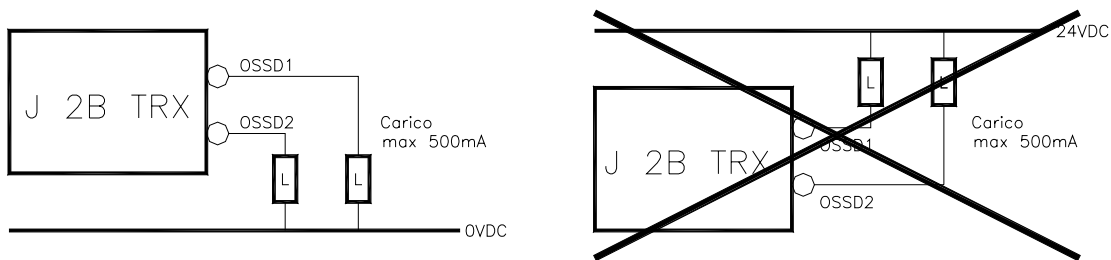

Figure 14

TECHNICAL SPECIFICATIONS

GENERAL DATA		
Safety category		4
Response time	ms	≤ 7
Working range	m	0 ÷ 6
Reset		automatic or manual selectable
Power supply	Vcc	24 ± 20%
Connections		M12 – 8 poles (male)
Protection rating		IP 65
Max. length of electrical connections	m	100
Dimensions light curtain section	mm	50 x 60
Operating temperature	°C	0 ÷ 55
Storage temperature	°C	-20 ÷ 70
Max operative humidity	%	95
Safety outputs		2 PNP auto-controlled – 500 mA @ 24 Vdc with short-circuit, overload, reversal of polarity protection
Max. output current	mA	500
System Status signal current	mA	100
Max. capacitive load	µF	2,2
Max. off-state voltage	V	< 1
Max. resistance of connections between OSSDs and the loads	Ohm	< 25
Max. consumption	W	6
Number of beams		2
Distance between beams	mm	500
Overall barrier ht.	mm	736 (J TRX E/R) - 723 (J TRX RR)
Light curtain lifetime		20 years
Safety level	Type 4	IEC 61496-1:2004 IEC 61496-2:2006
	SIL 3	IEC 61508:1998
	SILCL 3	IEC 62061:2005
	PL e - Cat. 4	ISO 13849-1 : 2006
PFHd *		3,96E-10
DCavg #		92,56%
MTTFd #	years	100
CCF #		80%

* IEC 61508

ISO 13849-1

DIMENSIONS

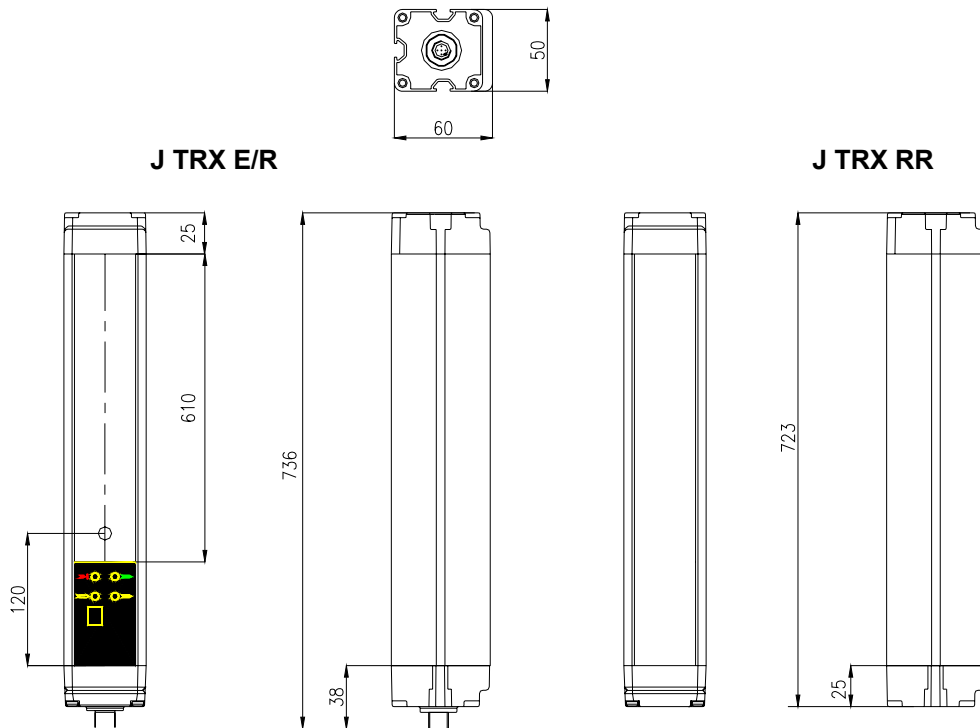

Figure 15

CHECKOUTS AND MAINTENANCE

Verification of barrier efficiency.



Before each work shift or before switching on, check the correct operation of the photoelectric barrier.

To execute this operation, Proceed as follows :

- Intercept each beam with an opaque object, first in the center of the detection zone and then close to the active and passive element.
- Verify that moving the test object close to the two beams, the red led (Figure 9) lights on.

The JANUS TRX barrier does not require any specific maintenance operations; however, periodic cleaning of the front protective surfaces of the active and passive unit optics is recommended.

Wipe using a clean, damp cloth; in particularly dusty environments, after cleaning the front surface, the use of an anti-static spray is recommended.

Never use abrasive or corrosive products, solvents or alcohol, which could damage parts. Do not use woollen cloths, that could electrify the front surface.

If the orange weak signal LED on the active unit switches on (LED 1 in Figure 9), check that:

- the front surfaces are clean;
- the active and passive elements are aligned correctly.

If the LED stays on, contact the REER service department.

TROUBLESHOOTING

The instructions shown on the display of the active element enable the user to identify the cause of a number of system malfunctions. As described in the “**SIGNALS**” paragraph of this manual, in case of a failure, the system is set to the stop condition and the display of the active element shows the letter F followed by a numerical code that identifies the type of failure. (See the tables below).

SYSTEM ERRORS (FIX SYMBOLS)

7 SEGMENTS DISPLAY		LED				REMEDY
SYMBOL	MEANING	RED	GREEN	YELLOW	ORANGE	
6	Short-circuit between the OSSD outputs	ON	OFF	OFF	OFF	Carefully check the connection of terminals 1 and 3 (OSSD) on the connector.
0	Overload of the OSSD outputs	ON	OFF	OFF	OFF	Carefully check the connection of terminals 1 and 3 (OSSD) on the connector. If necessary, adjust load reducing the current required to max 500 mA (2.2 μF).
1	Interfering dangerous Emitter detected. The receiver is able to receive simultaneously the beams from two different Emitters	ON	OFF	OFF	OFF	Carefully locate the interfering Emitter and take action in one of the following ways: <ul style="list-style-type: none"> • Move the interfering Emitter to avoid this illuminating the Receiver. • Shield the beams coming from the interfering Emitter using opaque protections.

SYSTEM ERRORS (BLINKING SYMBOLS)

7 SEGMENTS DISPLAY		LED				REMEDY
SYMBOL	SYMBOL	RED	GREEN	YELLOW	ORANGE	
F	Displayed alternatively to the error code	ON	OFF	OFF	OFF	-
3	Internal error (master board)	ON	OFF	OFF	OFF	Send the equipment for repair to the REER laboratories.
4	Internal error (master board)	ON	OFF	OFF	OFF	
5	OSSD static outputs error	ON	OFF	OFF	OFF	
A	Internal error (master board analog input)	ON	OFF	OFF	OFF	
C	Configuration error	ON	OFF	OFF	OFF	Carefully check the system configuration
H	User configuration changed without system restart	ON	OFF	OFF	OFF	Operate a system restart

In any case, when faced with a system stoppage, switch the system off and then on again, to exclude any occasional electromagnetic disturbances.

Should the problem persist, contact REER’s service department. In case of continued malfunctioning:

- verify the integrity of electrical connections and check that these have been made correctly;
- check that the supply voltage levels comply with those specified in the technical data sheet;

- the barrier power supply should be kept separate from that of the other electric power equipment (electric motors, inverters, frequency converters) or other sources of disturbance.
- make sure that the active element is correctly aligned and that the front surfaces are perfectly clean.



If it is not possible to clearly identify the malfunction and to remedy it, stop the machine and contact REER's Assistance Service.

If correct system operation cannot be restored after carrying out the above procedures, send the equipment to REER's laboratories, complete with all parts, stating clearly:

- the product code number (the **P/N** field is shown on the product label)
- serial number (the **S/N** field is shown on the product label)
- date of purchase;
- period of operation;
- type of application;
- fault.

SPARE PARTS

CONNECTORS		
C8D5	Straight 8-pin M12 female connector, 5 m cable	1330980
C8D10	Straight 8-pin M12 female connector, 10 m cable	1330981
C8D15	Straight 8-pin M12 female connector, 15 m cable	1330982
C8D95	90° 8-pin M12 female connector, 5 m cable	1330983
C8D910	90° 8-pin M12 female connector, 10 m cable	1330984
C8D915	90° 8-pin M12 female connector, 15 m cable	1330985
C8DM9	Straight 8-pin M12 female connector PG9	1330986
C8DM99	90° 8-pin M12 female connector PG9	1330987

FASTENING		
LH	Set of 2 fastening brackets LH type	7200127
FI 4	Set of 4 fastening inserts	1330972

GUARANTEE

All new JANUS TRX systems are guaranteed by REER for a period of 12 (twelve) months under normal working conditions, against defects due to faulty materials and workmanship. During the aforesaid period, REER promises to replace faulty parts free of charge. This guarantee covers both material and labour.

REER reserves the right to decide whether to repair equipment or replace it with equipment of the same type or having the same characteristics.

The validity of this guarantee is subject to the following conditions:

- The user must notify REER of the fault within twelve months following the date of delivery of the product.
- The equipment and all parts thereof must be in the condition in which they were supplied by REER.
- The defect or malfunction must not arise directly or indirectly from:
 - Improper use
 - Non-observance of the instructions for use;
 - Negligence, inexperience, improper maintenance;
 - Repairs, modifications and adjustments carried out by personnel not authorised by REER, tampering, etc.;
 - Accidents or collisions (also during transportation or due to acts of God);
 - Other reasons for which REER cannot be held responsible.

Repairs will be carried out at REER's laboratories, to which the material must be consigned or forwarded: transport costs and any damage or loss of material during transportation will be charged to the Customer.

All replaced products and parts are property of REER.

REER does not recognise any other form of guarantee or rights other than those expressly stated above; no requests for compensation for damages incurred for costs, suspension of activities or any other events or circumstances related in any way to malfunctioning of the product or any parts thereof will be taken into consideration.

In order to ensure the correct operation of the photoelectric barrier, careful and full compliance with all the rules, instructions and warnings stated in this manual is essential. REER s.p.a. declines all responsibility for events arising from non-compliance with all or part of the aforesaid instructions.

Specifications subject to change without warning. • No part of this manual may be reproduced without the prior consent of REER.